

HIGH LIFT PALLET TRUCK

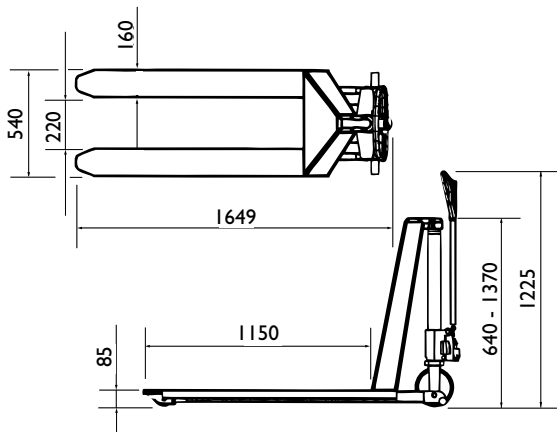

Standard - handy and simple to use

- Positions the load at a comfortable, ergonomically correct working height
- Fitted as standard with Quick-Lift
- Lifts 38 mm per pump stroke with 450 kg load, 20 mm with heavier load
- Protection valve protects the lifter from overload
- Automatically activated stabilisers when lifting height exceeds 400 mm
- Polyurethane fork wheel
- Polyurethane wheels are noiseless and offers maximum surface protection



Telescopic cylinder



Fitted with stabilisers



SLP1000

| Model | | SLP1000 |
|---------------------|----|--------------|
| Lifting capacity | kg | 1000 |
| Lifting function | | Manuel |
| Lifting height | | 800 |
| Steering/Fork wheel | | Ø 180 / Ø 80 |
| Fork length | | 1150 |
| Fork width | | 540 |
| Wheel type | | Polyurethane |
| Weight | kg | 110 |
| Product no. | | 8533265 |